



PARTS BOOK

SKID LOADER HEADS
• FORESTRY •

DIAMOND MOWERS, Inc.
350 E 60th St. North
Sioux Falls, SD 57104

FOR WARRANTY CALL DIAMOND MOWERS DIRECT:
888-960-0364
OUR TECHNICIANS WILL DIAGNOSE YOUR SITUATION
OVER THE PHONE TO GET YOU UP AND RUNNING QUICKLY.

Phone: 605-977-3300
Fax: 605-655-5870
www.diamondmowers.com

DEMAND BRILLIANCE.

© DIAMOND MOWERS, INC.



Foreword

This manual contains the parts breakdown and identification of the various components and structures that make up your mower implement.

The illustrations, drawings, and diagrams in this manual are based on the latest information available at the time of publication. Your machine may have product improvements and features not yet contained in this parts manual.

Diamond Mowers Inc. reserves the right to make changes at any time without notice or obligation.

Diamond Mowers Inc.[™] and Wetblade[™] are trademarks of Diamond Mowers Inc.

This manual should be consulted prior and while assembling the unit, and anytime parts or assembly clarification is needed.

Copyright© 2016 Diamond Mowers Inc.

All rights reserved. While every precaution has been taken in the preparation of this manual, the publisher assumes no responsibility for errors or omissions. No part of this book covered by the copyrights heron may be reproduced or copied in any form or by any means - graphic, electronic, or mechanical, including photocopying, taping, or information storage and retrieval systems - without written permission of the publisher.



Table of Contents

FORESTRY HEADS	4
FORESTRY HEAD - 60" DECK, DIRECT DRIVE.....	5
DRIVE ASSEMBLIES	6
HOW TO DETERMINE YOUR MOTOR PART NUMBER.....	7
DRIVE ASSEMBLY - 60", 32-45 GPM.....	8
DECK ASSEMBLIES	9
30-0524 - MOTOR ASSEMBLY.....	10
35-0093 - DIRECT DRIVE SPINDLE.....	11

FORESTRY HEADS



FORESTRY HEAD - 60" DECK, DIRECT DRIVE

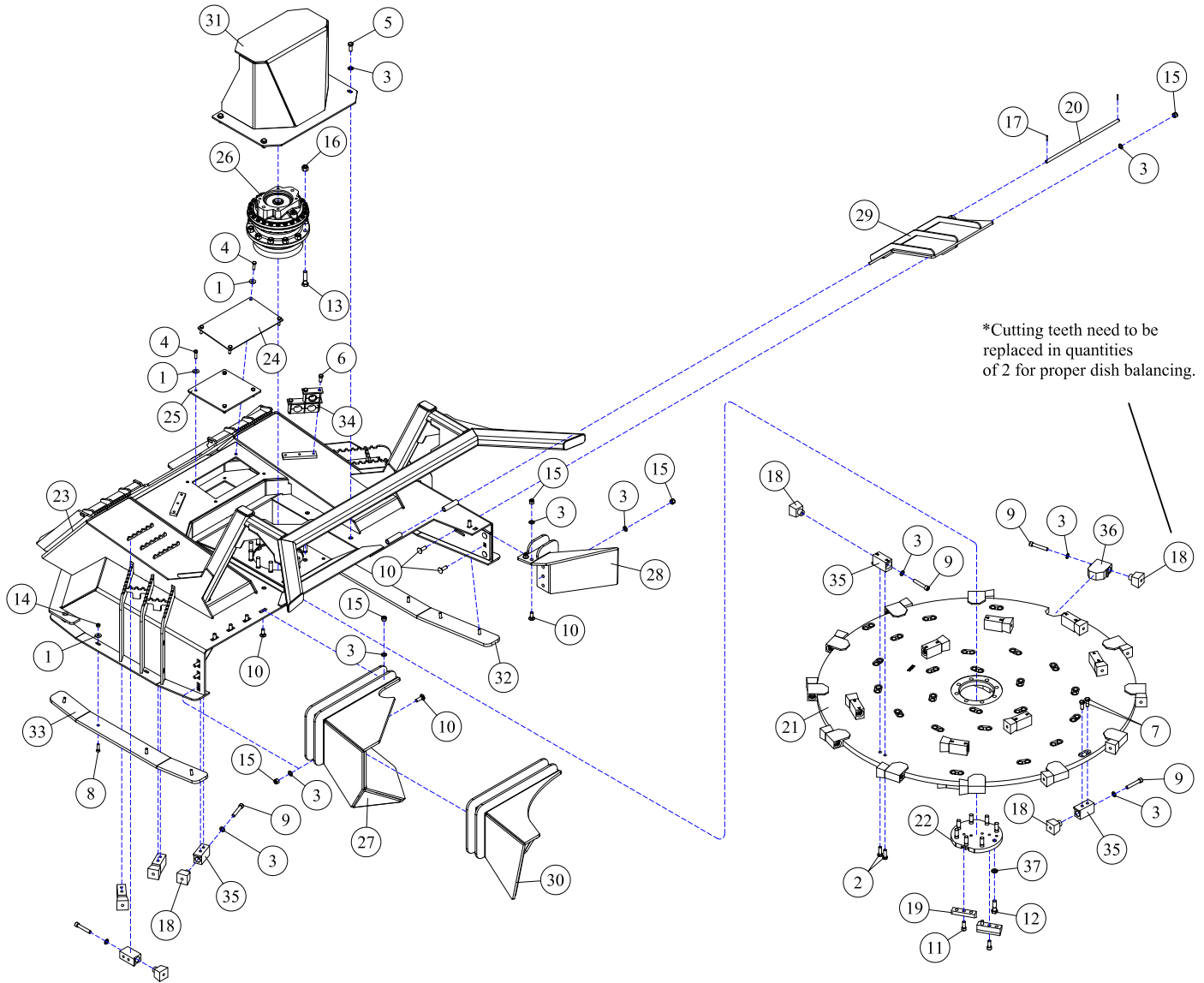

*Cutting teeth need to be replaced in quantities of 2 for proper dish balancing.

REF#	PARTS DESCRIPTION	REQ	PART #
1	3/8 FLAT WASHER GR 5 CLEAR	18	11-0009
2	1/2 X 1-1/2 H.S.NF HEX CAP	16	11-0704
3	1/2 SAE FLAT WASHER GR 8 YELLOW	65	11-0042
4	3/8 X 1 NC HEX CAPSCREW	8	11-0532
5	1/2 X 1-1/4 NC HEX CAP	4	11-0570
6	7/16 X 1 NC HEX CAPSCREW	3	11-0584
7	1/2 X 1 NF HEX CAP GR 5	48	11-0639
8	3/8 X 1-1/2 PLOW BOLT	9	11-0795
9	1/2 X 3 NF SHCS	48	11-0929
10	1/2 X 1-3/4 NC CARRIAGE BOLT GR 8	13	11-0961
11	1/2 X 1-1/4 NC SHCS	6	11-0965
12	5/8 X 2 NC HEX CAPSCREW, GR 8	8	11-0970
13	5/8 X 2-1/2 NC HEX CAPSCREW, GR 8	12	11-0971
14	3/8 NC NYLOCK NUT GR 5	9	11-1024
15	1/2 NC NYLOCK NUT GR 8	13	11-1072
16	5/8 NC NYLOCK NUT GR 8	12	11-1073
17	ROLL PIN, 5/32 X 1	2	11-2054
18	*STEEL CUTTING TOOTH	48	22-0019
19	FBC, CENTER PLANNER	2	24-0192
20	DEFLECTOR HINGE ROD	1	24-0213
21	60 FBS DISH, COMPLETE	1	24-0223
22	FBS, BOLT PROTECTOR	1	24-0224

REF#	PARTS DESCRIPTION	REQ	PART #
23	SKID DECK	1	25-0204
24	UPPER ACCESS PORT COVER	1	31-0537
25	LOWER ACCESS PORT COVER	1	31-0455
26	SPINDLE ASSEMBLY	1	35-0093
27	NARROW CHUTE	1	41-1302
28	LEFT CHUTE	1	41-1303
29	DEBRIS DEFLECTOR	1	41-1305
30	WIDE CHUTE	1	41-1307
31	MOTOR GUARD	1	41-1461
32	LEFT SKID SHOE	1	42-0048
33	RIGHT SKID SHOE	1	42-0049
34	HOSE CLAMP	1	44-0351
35	TOOTH HOLDER, INSIDE	36	90-7035
36	TOOTH HOLDER, OUTSIDE	12	90-7036
37	5/8 LOCK WASHER GR 8	8	11-0043
38	TOOTH KIT		
	Kit 44-0342 includes 20 each of parts 3, 9, 18.	1	
	Kit 44-0341 includes 50 each of parts 3, 9, 18.	1	
39	COMPLETE TOOTH KIT		
	Kit 44-0330 includes 47 each of parts 3, 9, 18, 6 each of part 11, and 2 each of part 19.	1	

DRIVE ASSEMBLIES



HOW TO DETERMINE YOUR MOTOR PART NUMBER

Note: The following parts pages in the **DRIVE ASSEMBLIES** section have multiple motor options; to identify which motor you have, follow the instructions below: you will have to first determine your vehicles hydraulic oil GPM requirements (i.e. 16-41gpm).

- ▷ Determine what your hydraulic oil flow requirements are for your vehicle in gallons per minute (GPM).
- ▷ Locate the **Drive Assemblies** page in the table of contents in the front of this manual that has a GPM range consistent with your vehicle's GPM requirements, and go to that page. Locate your motor part number.
- ▷ If multiple motor options and part numbers are available on your parts page, measure the width of the gear set portion of your motor to determine which part number is correct for your motor. Measure the gear set as shown in the illustration below *(see Figure 1)*.

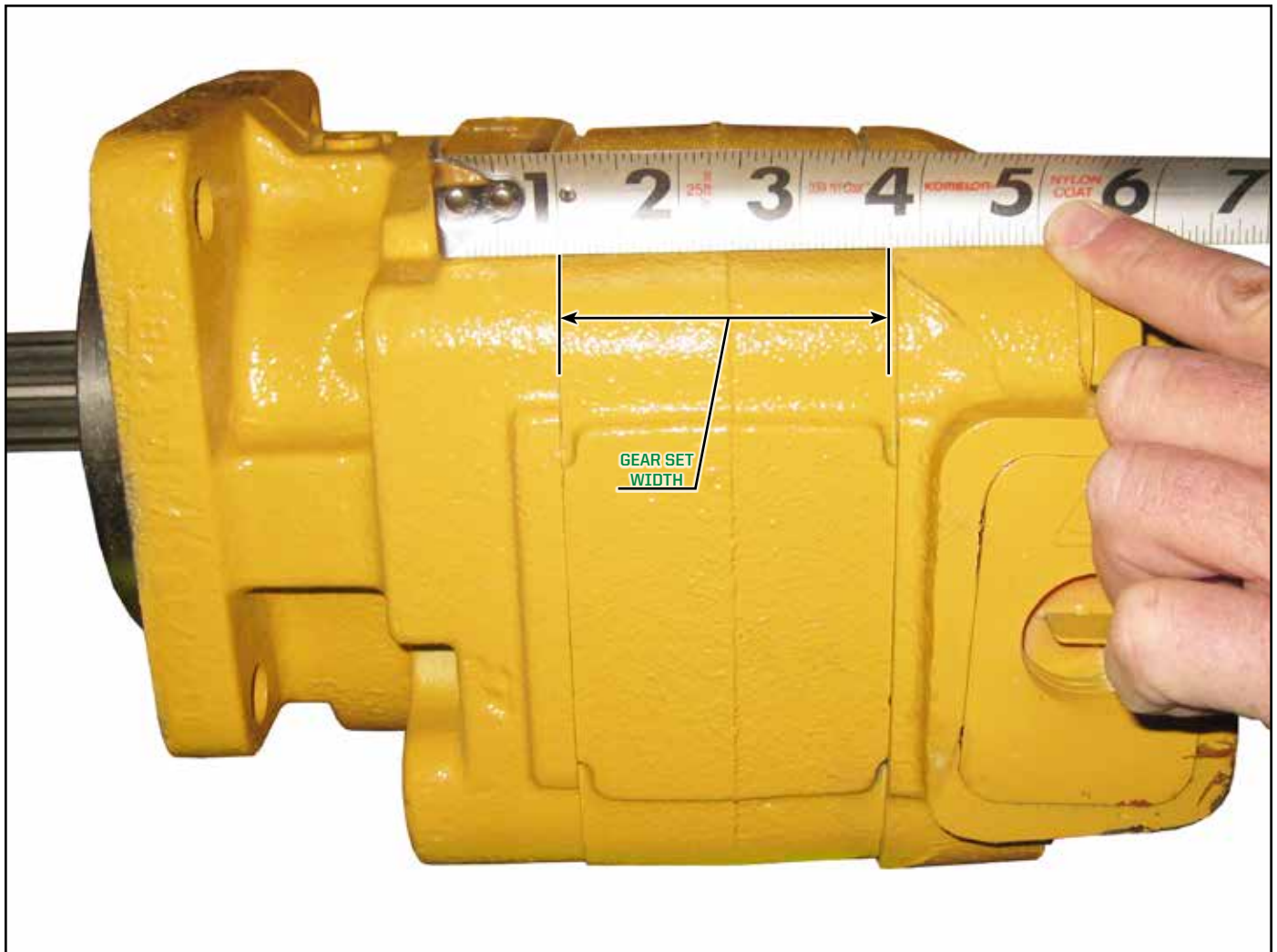

Motor - (Figure 1)

DRIVE ASSEMBLY - 60", 32-45 GPM

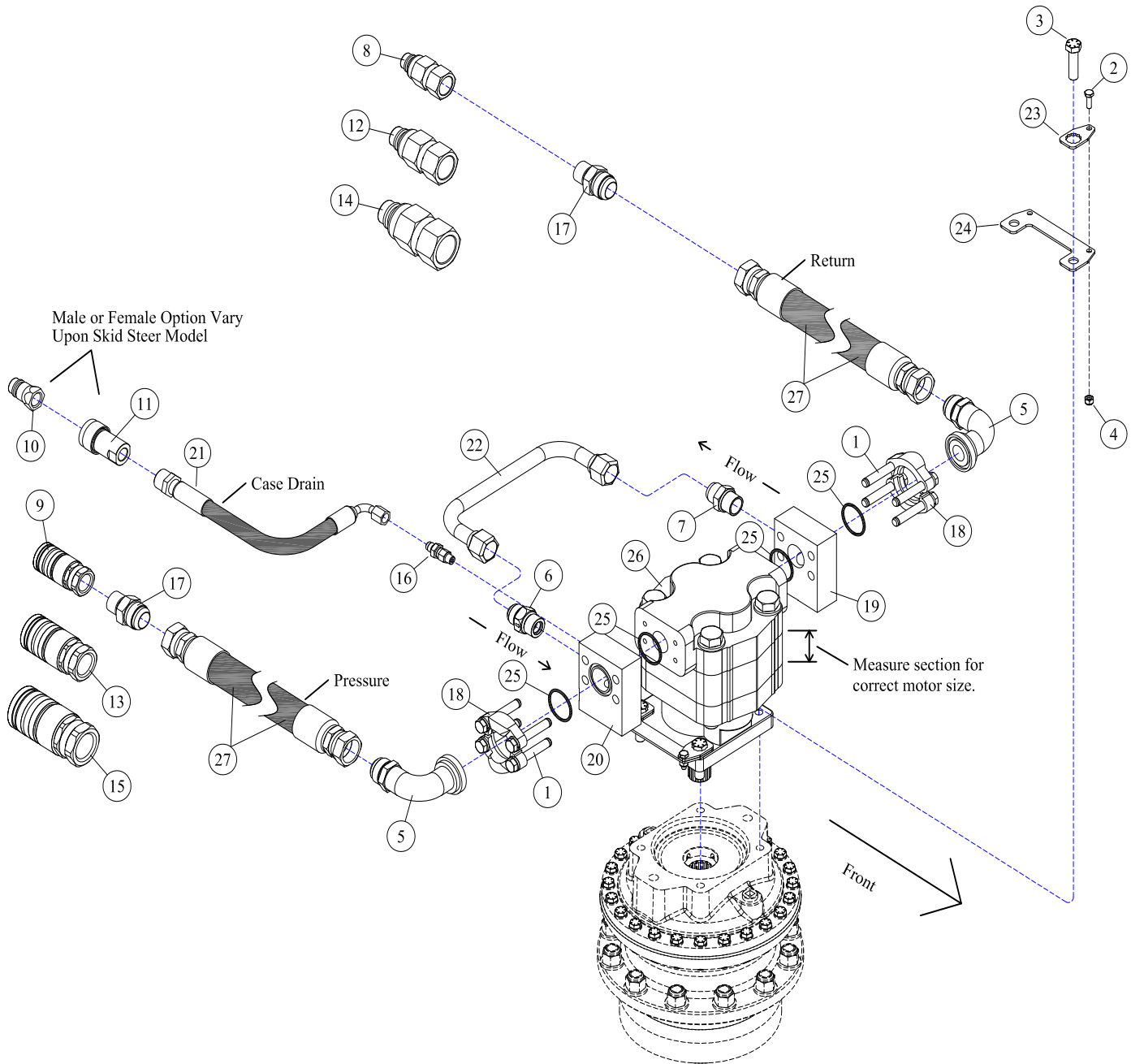

REF#	PARTS DESCRIPTION	REQ	PART #
1	7/16 X 3 NC HEX CAPSCREW (included with #19 & 20)	8	11-0587
2	1/4 X 3/4 NC HEX CAP	4	11-0588
3	1/2 X 1-1/2 NC HEX CAP, GR 8	4	11-0972
4	1/4 NC NYLOCK NUT	4	11-1022
5	#20FLGX 1MJIC-90DEG ADAPTER	2	21-1267
6	CHECK VALVE	1	21-1474
7	3/4 MORB X 3/4 MJIC ADAPTER	1	21-1475
8	1/2 MALE QUICK COUPLER, FLAT FACE	1	21-1559
9	1/2 FEMALE QUICK COUPLER, FLAT FACE	1	21-1560
10	3/8 MALE QUICK COUPLER, FLAT FACE	1	21-1561
11	3/8 FEMALE QUICK COUPLER, FLAT FACE	1	21-1562
12	5/8 MALE QUICK COUPLER, FLAT FACE	1	21-1574
13	5/8 FEMALE QUICK COUPLER, FLAT FACE	1	21-1575
14	3/4 MALE QUICK COUPLER, FLAT FACE	1	21-1576
15	3/4 FEMALE QUICK COUPLER, FLAT FACE	1	21-1577
16	ADAPTER, 1/4MOR X 3/8MJIC	1	21-1597

REF#	PARTS DESCRIPTION	REQ	PART #
17	ADAPTER, 1MJIC X 3/4MORB	2	21-1602
18	#20 FLANGE KIT (included with #19 & 20)	2	21-2105
19	CROSS OVER MANIFOLD KIT (includes #1, 18 & 25)	1	21-2180
20	TEE MANIFOLD KIT (includes #1, 18 & 25)	1	21-2181
21	HOSE 3/8 X 106 (3/8FJIC 90DEG X 1/2MP)	1	21-4290
22	RUN-AROUND TUBE	1	28-0051
23	MOTOR BOLT LOCK TAB	4	31-0503
24	MOTOR BOLT LOCK BASE	2	31-0504
25	O-RING (included with #18, 19 & 20)	4	33-0013
26	MOTOR		
	M365, 2-1/4" GEAR SET, 2-3/4" SECT, 32-45 GAL/MIN	1	30-0524
27	HOSE 1" (1FJIC X 1FJIC)		
	"STANDARD", PRESSURE & RETURN 103"	2	21-4345
	"OPTIONAL UPGRADE" 4000 psi, PRESSURE 103"	1	21-4346
	"OPTIONAL UPGRADE" 4000 psi, RETURN 90"	1	21-4365

DECK ASSEMBLIES



30-0524 - MOTOR ASSEMBLY

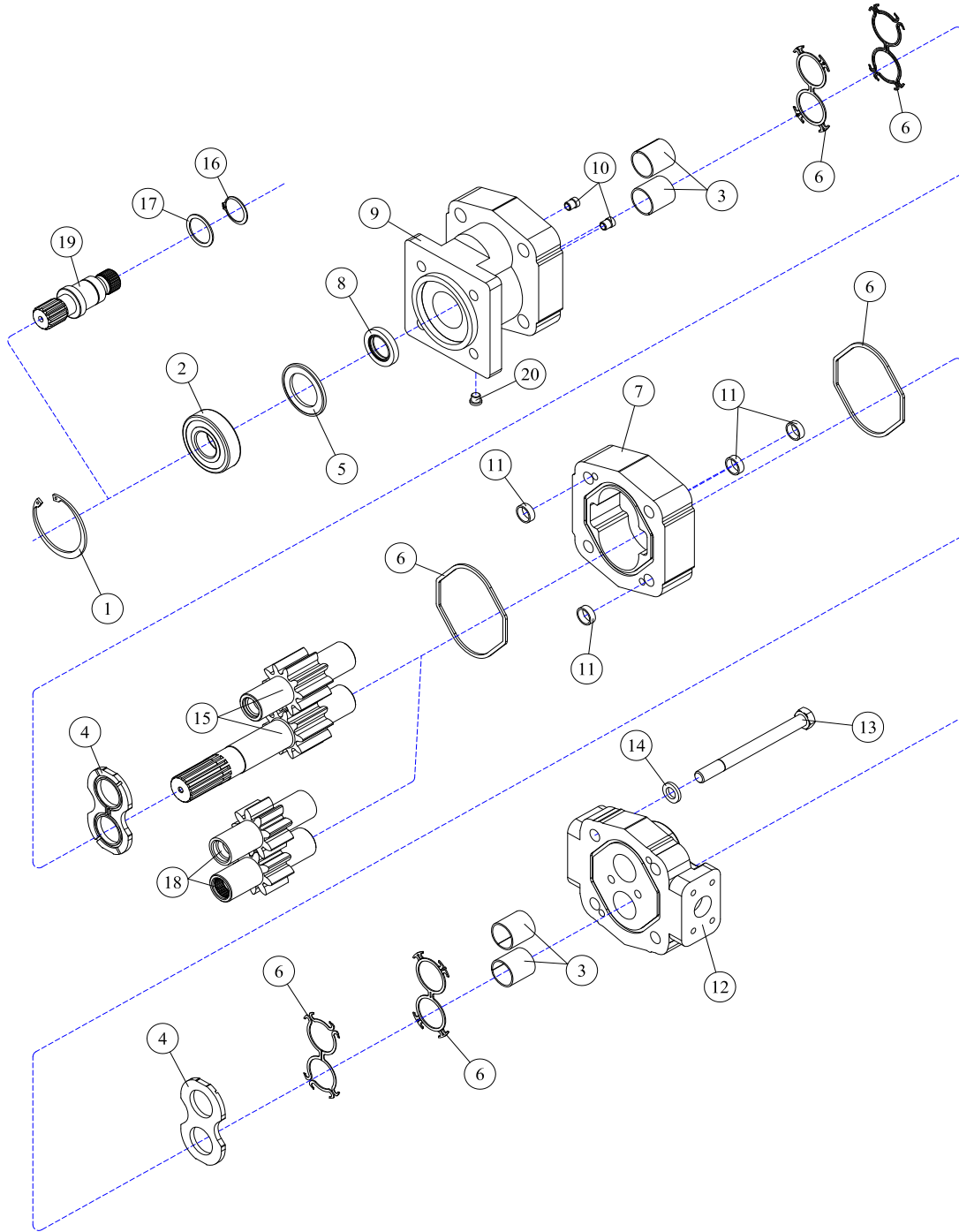

REF#	PARTS DESCRIPTION	REQ	PART #
1	SNAP RING	1	30-1009
2	OUTBOARD BEARING	1	30-1010
3	BUSHING	4	30-1011
4	THRUST PLATE	2	30-1012
5	SEAL RETAINER	1	30-1017
6	M365 SEAL KIT	Avail	30-1021
7	2-1/4" M365 GEAR HOUSING	1	30-1026
8	SHAFT SEAL		
	150 PSI (included in M365 seal kit)	1	30-1210
	500 PSI	1	30-1156
9	SHAFT END COVER	1	30-1086
10	CHECK ASSEMBLY	2	30-1087
11	ALIGNMENT BUSHING	4	30-1090

REF#	PARTS DESCRIPTION	REQ	PART #
12	PORT END COVER	1	30-1091
13	STUD	4	Call
14	WASHER	4	30-1093
	GEAR SET OPTION A:		
15	2-1/4" GEAR SET	1	30-1165
	GEAR SET OPTION B:		
16	RETAINING RING	1	30-1019
17	WASHER	1	30-1020
18	2-1/4" GEAR SET	1	30-1025
19	CONTINENTAL SHAFT, SPLINED	1	30-1144
20	PLUG	1	30-1096
*	SEAL APPLICATOR TOOL (not shown)	Avail	30-1048

35-0093 - DIRECT DRIVE SPINDLE

REF#	PARTS DESCRIPTION	REQ	PART #
1	BEARING-CONE (TOP)	1	10-0094
2	BEARING-CUP (TOP)	1	10-0095
3	BEARING-CONE (BOTTOM)	1	10-0096
4	BEARING-CUP (BOTTOM)	1	10-0097
5	BOLT-HEX HEAD	24	11-1611
6	WASHER-FLAT	24	11-1612
7	RING-RETAINING	1	11-1613
8	NUT-LOCK	1	11-1614
9	WASHER-LOCK	1	11-1615
10	SCREW-SKT HD CAP	6	11-1616
11	PIPE PLUG (TO COVER) (MAGNETIC)	1	21-1609
12	PIPE PLUG (TO COVER) (NON-MAGNETIC)	1	21-1610
13	PIPE PLUG (TO HUB) (MAGNETIC)	2	21-1611
14	WASHER-THRUST (TOP)	1	35-0096
15	COUPLING	1	35-0097
16	PLATE-KEEPER	1	35-0098
17	WASHER-THRUST (BOTTOM)	1	35-0099
**18	HUB	1	35-0100
19	SEAL-OIL	1	35-0101
*20	GUARD	1	35-0102
**21	SHAFT-OUTPUT	1	35-0103
22	COVER		
	C BASE (STANDARD)	1	35-0094
	D BASE (OPTIONAL)	1	35-0095

NOTE: WHEN ORDERING ANY ITEMS MARKED * ABOVE, ALSO ORDER SERVICE KIT 33-0078

NOTE: WHEN ORDERING ANY ITEMS MARKED ** ABOVE, ALSO ORDER SERVICE KIT 33-0079

SERVICE KITS

PART #	DESCRIPTION	INCLUDED ITEMS
33-0078	SEAL KIT	9, 19
33-0079	BEARING & SEAL KIT	1, 2, 3, 4, 9, 19
33-0080	COUPLER KIT	14, 15

KITS ALSO INCLUDE A TUBE OF SEALANT PART NO. 35-0104

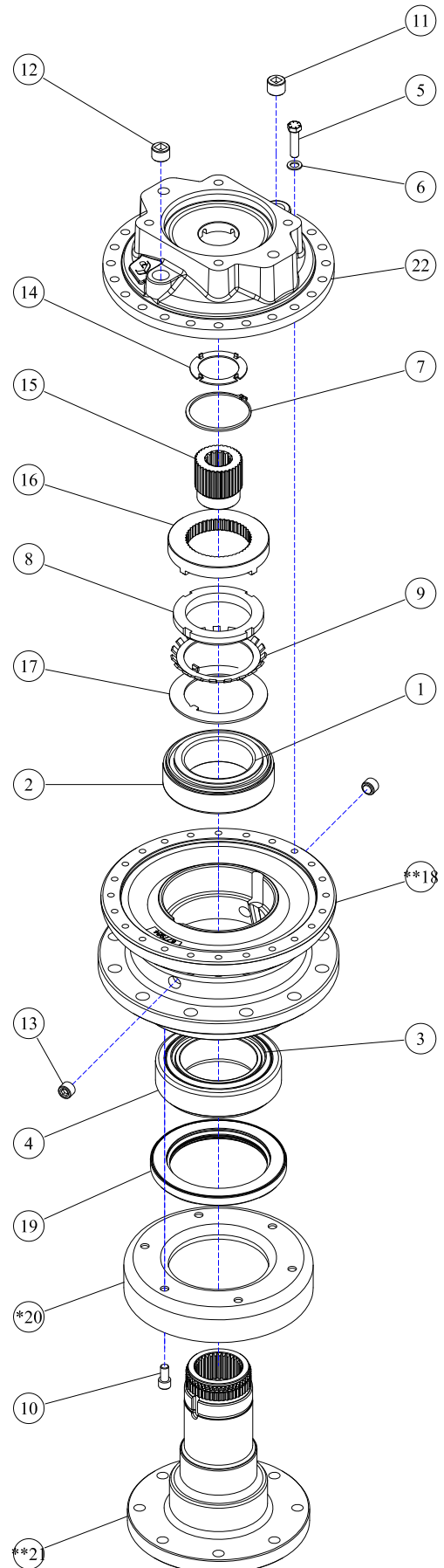



**100% SATISFACTION
GUARANTEE**
★ GET IT, LOVE IT, *or* LEAVE IT! ★

**72-HOUR PARTS
SHIPPING GUARANTEE**